

Policy No.: _____

Insured: _____

Agent: _____

Location of Risk: _____

WOOD/COAL BURNING FACILITY QUESTIONNAIRE

REQUIREMENTS

1. A photo of the wood/coal burning facility must be submitted with this Questionnaire.
2. Questionnaire and photo must be submitted with application for insurance.
3. Questionnaire must be inspected and signed by a licensed contractor or member of local fire department when facility is NOT factory installed or commercially installed by appliance distributor or licensed expert.

STOVE INFORMATION

TYPE	<input type="checkbox"/> Radiant <input type="checkbox"/> Circulating <input type="checkbox"/> Franklin <input type="checkbox"/> Other (specify): _____		
MAKE/NAME	By: _____	U.L. Approved? <input type="checkbox"/> Yes <input type="checkbox"/> No	
USE	<input type="checkbox"/> Primary Heat <input type="checkbox"/> Auxiliary Heat <input type="checkbox"/> Cooking <input type="checkbox"/> Other (specify): _____		
INSTALLED	By: _____	Date: _____	
FLOOR PROTECTION	<input type="checkbox"/> Asbestos Millboard Covered with Metal <input type="checkbox"/> Metal <input type="checkbox"/> Stone/Brick <input type="checkbox"/> Other(specify below)		
WALL PROTECTION	<input type="checkbox"/> Asbestos Millboard Covered with Metal <input type="checkbox"/> Metal <input type="checkbox"/> Asb. Millbrd <input type="checkbox"/> Other(specify below)		
CHIMNEY & STOVE PIPES	CHIMNEY TYPE: <input type="checkbox"/> Factory <input type="checkbox"/> Masonry <input type="checkbox"/> Other (describe): _____		
	How often checked for creosote build-up? _____		
	Date Last Cleaned: _____		By Whom? _____
	Does vent pass through a combustible partition? <input type="checkbox"/> Yes <input type="checkbox"/> No		
	If yes, is protection thimble or sleeve used? <input type="checkbox"/> Yes <input type="checkbox"/> No		
	Does pipe vent pass directly through the roof? <input type="checkbox"/> Yes <input type="checkbox"/> No		
	Are any other heating units vented to chimney? <input type="checkbox"/> Yes <input type="checkbox"/> No (describe below)		
Is stove vent system equipped with heat reclaiming unit or flue radiator? <input type="checkbox"/> Yes <input type="checkbox"/> No			

CLEARANCES

1. Side of unit to nearest wall __ inches.
 2. Rear of unit to wall __ inches.
 3. Top of stovepipe to ceiling __ inches.
 4. Bottom of unit to floor __ inches.
 5. Front of unit to front edge of floor protection __ inches.
 6. Size of stovepipe used __ inches.
 7. Size of thimble or roof joist shield __ inches.
- Do these distances comply with the manufacturer's standards? Yes No

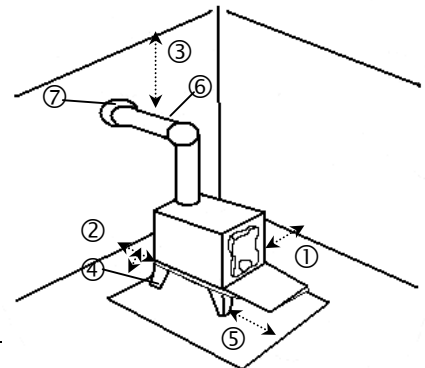

MISCELLANEOUS

FUEL	<input type="checkbox"/> Wood <input type="checkbox"/> Coal <input type="checkbox"/> Other (specify): _____		
PREVENTION	Fire Extinguisher in Room? <input type="checkbox"/> Yes <input type="checkbox"/> No	Smoke Alarm? <input type="checkbox"/> Yes <input type="checkbox"/> No	
ADDITIONAL REMARKS			

Inspector Signature: _____

Date Inspected: _____

PHOTO MUST BE ATTACHED